

A Horizontal Loop for 80-Meter DX

Working DX on 80 meters doesn't necessarily require big towers or trees. This 80-meter quad loop system requires only supports of modest height—a better single-element antenna may be hard to find.

Introduction

In 1997 the author published an article on vertical full (and ground plane type half) wave loops for 80 meter DX.¹ In that article it was noted that perpendicular (horizontal) polarization is the preferred polarization, particularly at low elevation angles, since horizontally polarized waves are hardly affected by the finite conductivity of the ground in front of the antenna. An exception when vertical antennas come into their own is a vertically polarized antenna over very good ground, near the seashore or over alkaline salt flats.

A practical 80 meter horizontal dipole is, however, not an ideal antenna for DX. For optimum communications with distant stations the antenna's radiation pattern should have a null overhead, to minimize near vertical incidence sky-wave signals from atmospheric noise and interference, and a low angle lobe to maximize reception/transmission over paths to distant stations. To achieve such a pattern with a half-wave dipole it would be necessary to install the dipole a half wavelength above the ground, that is to say, at a height of 40 meters for the 80 meter band. This is impractical in many instances.

A full-wave horizontal loop for the 80 meter band at a practical height of 15 meters is a popular antenna nicknamed a "Loop Skywire" that has been in *The ARRL Antenna Book* for years. In the author's view this antenna does not have the desired radiation pattern for 80 meter DX. Aside from the fact that the direct and ground-reflected waves reinforce at an elevation angle of 90°, the loop itself has some directivity in this broadside direction. Doug DeMaw has referred to such an antenna as a "cloud warmer."

Paul Carr, N4PC proposed a solution for this problem.² He fed diagonally opposite corners of a square loop with equal but oppositely phased currents. For a full-wave loop this produces a null in the overhead radiation pattern, akin to the time-honored W8JK array—a pair of closely spaced dipoles fed out of phase.³ For 80 meters N4PC used a $3/4$ -wavelength loop, which had the desired elevation pattern, but with corner feed the azimuthal pattern is skewed compared with the loop modeled by the author.

According to the author's simulation using W7EL's *EZNEC Pro* version of the numerical electromagnetic code NEC-4D, the antenna's impedance at the input

to a transmission line feeder of practical length, is not a particularly convenient value to tune and match. N4PC did not comment on this. In fact, he did not include the phasing and the feeder transmission lines in his model, and so he could not comment on the input impedance of his antenna system although he reported "no problem with tuning and matching his antenna on all bands 80 through 10 meters."

In this article the author uses numerical simulation to address the radiation characteristics and the tuning and matching details of a symmetrical full wave quad loop designed specifically for 80 meter DX.

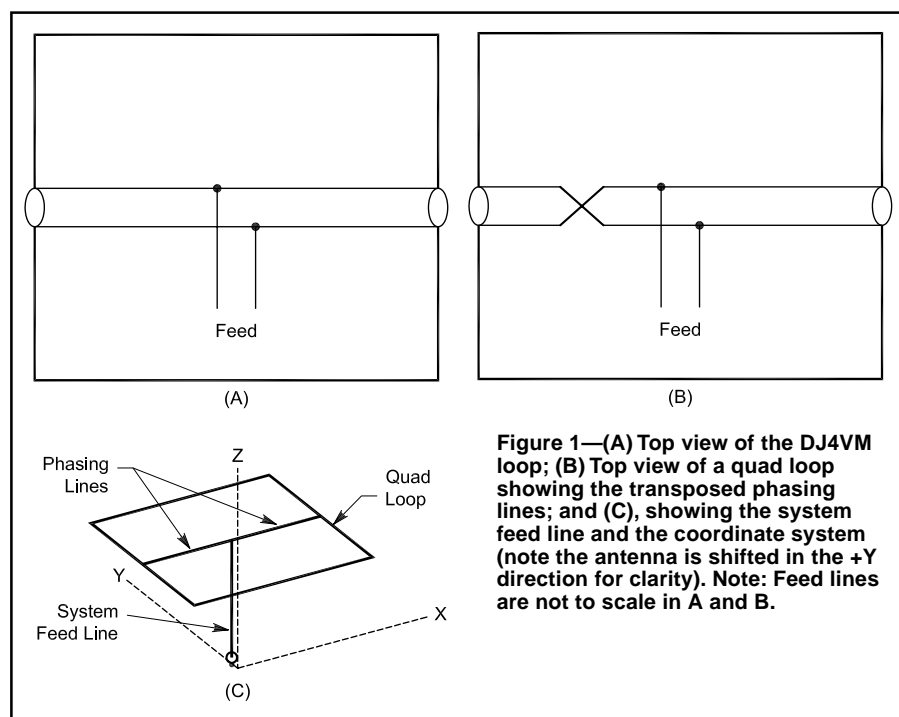
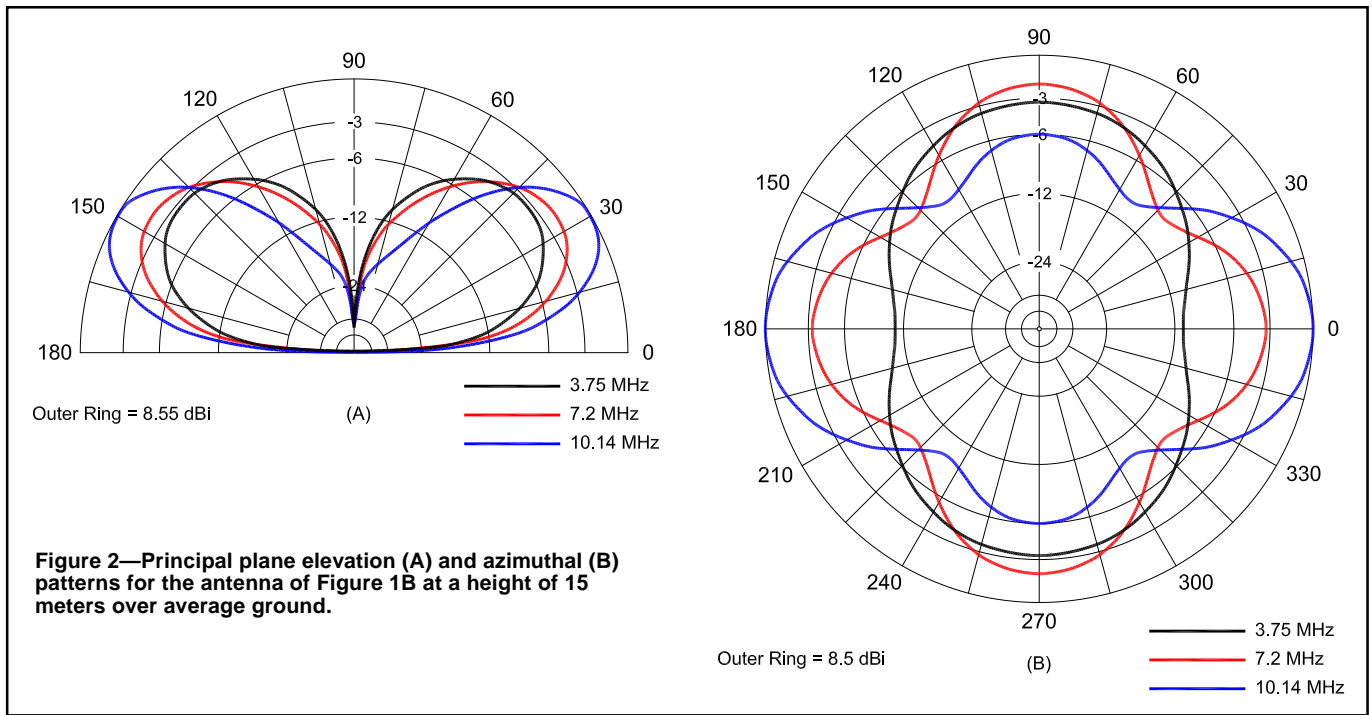

Figure 1—(A) Top view of the DJ4VM loop; (B) Top view of a quad loop showing the transposed phasing lines; and (C), showing the system feed line and the coordinate system (note the antenna is shifted in the +Y direction for clarity). Note: Feed lines are not to scale in A and B.

¹Notes appear on page 35.



A Horizontal Square Loop with a W8JK-Like Radiation Pattern

W. Bolt, DJ4VM, described a multi-band vertical quad loop with both of the vertical sides fed in-phase by means of a “phasing line.”⁴ This symmetrical feed arrangement (Figure 1A) has the advantage of ensuring a symmetrical current distribution on the loop—and hence a “clean” radiation pattern over several bands (40 meters to 10 meters).

Our interest here, however, is a horizontally polarized loop operating in “W8JK mode.” Rotating the plane of his loop 90°, we now have the horizontal loop, in which the system feed line connecting at the center of the phasing lines can drop vertically at right angles to the plane of the loop (see Figure 1C). The symmetry of this loop arrangement is appealing.

The author decided to carry out a detailed numerical modeling study for this loop fed with a balanced, transposed phasing transmission line (opposite sides of the loop fed out of phase). The horizontal full wave loop, $\lambda/4$ or 20 meters on a side for 3.75 MHz, at a height of 15 meters over average ground, is numerically modeled as three separate cases:

Case 1) Out-of-phase sources placed at the centers of the sides of the loop (the sides parallel to the Y-Z plane);

Case 2) Wires are added for the conductors of a 600- Ω phasing line between the opposite sides with the source placed at the middle. (Note: The conductors for the transmission line feeding the side of

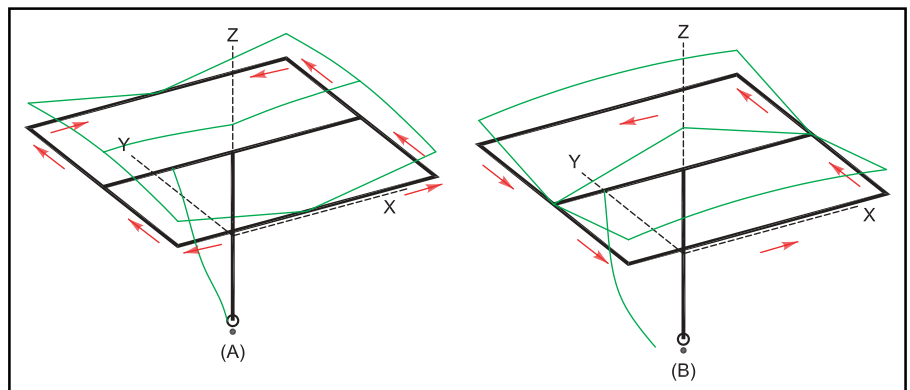

Figure 3—Horizontal quad loops showing currents on the loop wires for the case where the phasing lines provide in-phase feed (A); and out-of-phase feed (B). Note the left phasing line is the transposed feeder. The frequency is 3.75 MHz.

the loop in the $-X$ direction are transposed to provide the out-of-phase feed; see Figure 1B.)

Case 3) Case 3 differs from Case 2 only in that a system feed transmission line is added, with the source on a jumper wire between the transmission line conductors at its bottom or transmitter end (Figure 1C).

All wires are no. 12 copper. The spacing for the conductors of the transmission lines is 150 mm (for an impedance $Z_o = 600 \Omega$). The length of the transmission line feeder is 14 meters.

The reason for the three-case modeling sequence is to be sure that the transmission lines included in the model are performing correctly. We find that they are by computing the feedpoint impedances of the two models with different techniques.

The NEC-4D input impedance for the Case 3 antenna at 3.75 MHz is $9.8 + j462 \Omega$. For the Case 2 antenna, fed by a 600- Ω open wire transmission line 14 meters long, the input impedance is $9.9 + j464 \Omega$ according to TL, the transmission line program by N6BV and published by the ARRL.

While the source impedances are, of course, different for all three configurations, radiation patterns are substantially identical. The maximum gain is decreased slightly with the addition of the transmission lines as would be expected because of the high SWR on the transmission lines (see below). At 3.75 MHz, the gains in the principal plane (the Y-Z plane) are 6.02 dBi, 5.34 dBi and 3.93 dBi, for cases 1, 2 and 3, respectively. From this point, all discussion will be of the antenna sys-

tem of Case 3 and “system impedance” will refer to the impedance at the transmitter end of the common feed line.

The principal plane radiation pattern is shown in Figure 2 at a frequency of 3.75 MHz. For interest, the pattern is also shown at 7.2 MHz, and 10.14 MHz. The calculated antenna system impedances and radiation characteristics (gain and take-off angle, ψ , are given in Table 1).

We are concerned here with the radiation pattern for 80 meter DX. Clearly the radiation patterns shown in Figure 2 are almost ideal: a deep overhead null, and a bidirectional pattern with a take-off angle (41°) that is low for the practical height (15 m) of the loop. The azimuthal pattern is also good (for an 80 meter antenna) with a front-to-side ratio about 10 dB.

Clearly, at 3.75 MHz, conductor loss in the system feeder transmission line attached to the junction of the phasing lines will be an important consideration because of the high SWR. For an open wire line 14 meters long made of no. 12 wire the transmission line loss is 1.5 dB, according to NEC-4D. By using a larger diameter wire, the loss can be reduced. As an example of the benefits of using heavy-duty transmission lines, if the conductors were no. 4 copper wire, the transmission line loss would be 0.5 dB. For this calculation the spacing for the larger diameter wire is 150 mm so that Z_0 is less than 600 Ω , but the characteristic impedance for this feeder

Table 1
Impedance at the Junction of the Phasing Lines for Out of Phase Feed (W8JK-like Mode)

Frequency (MHz)	Impedance (Ω)	Gain (dBi)	Take-off Angle (ψ)
3.75	$5.5 - j 310$	5.34	41°
7.2	$285 + j 654$	6.61	34°
10.14	$73 + j 84$	8.55	32°

is relatively unimportant. The transmission line loss at 7.2 MHz and 10.14 MHz is negligible. [While quite large, no. 4 wire is commonly used for electrical grounding. The outer shield of coaxial cable could also be used to construct an open wire line with large conductors.—Ed.]

Current Distribution on the Loop

To understand how the patterns for in-phase and out-of-phase feed come to be, it is interesting to look at the current distributions on the loop. Figure 3 shows the current distribution (amplitude only) and by arrows the relative phase relationship for the DJ4VM-type loop with opposite sides fed in phase, and for the same loop configured with opposite sides of the loop fed out-of-phase to radiate in “W8JK mode.” Phase information is useful in determining that certain kinds of antennas are modeled correctly. For closed loops, particularly for the case with dual sources, the phase as calculated

by NEC can be confusing.

Sudden reversals in phase may not be a cause of concern if they result from the way the wires have been defined. Positive current is defined as being from end 1 to end 2 of the wire, so if for two wires end 1 is connected to the other end 1, a 180° shift in current phase will be indicated at the junction of the wires. The actual current is continuous, as it should be, but the direction reference changes from one wire to the other. This can lead to confusion, particularly for closed loops such as our present model where in Case 1 the loop is fed in the center of two sides (two sources and no transmission lines). If the quad loop is modeled with end 1 connecting to end 2 for all wires, opposite sides will have wires defined in opposing directions. For the desired radiation pattern, the phase relationship of the sources in the model will then be 180° different from those of the actual antenna.

That is why in Figure 3 we show the

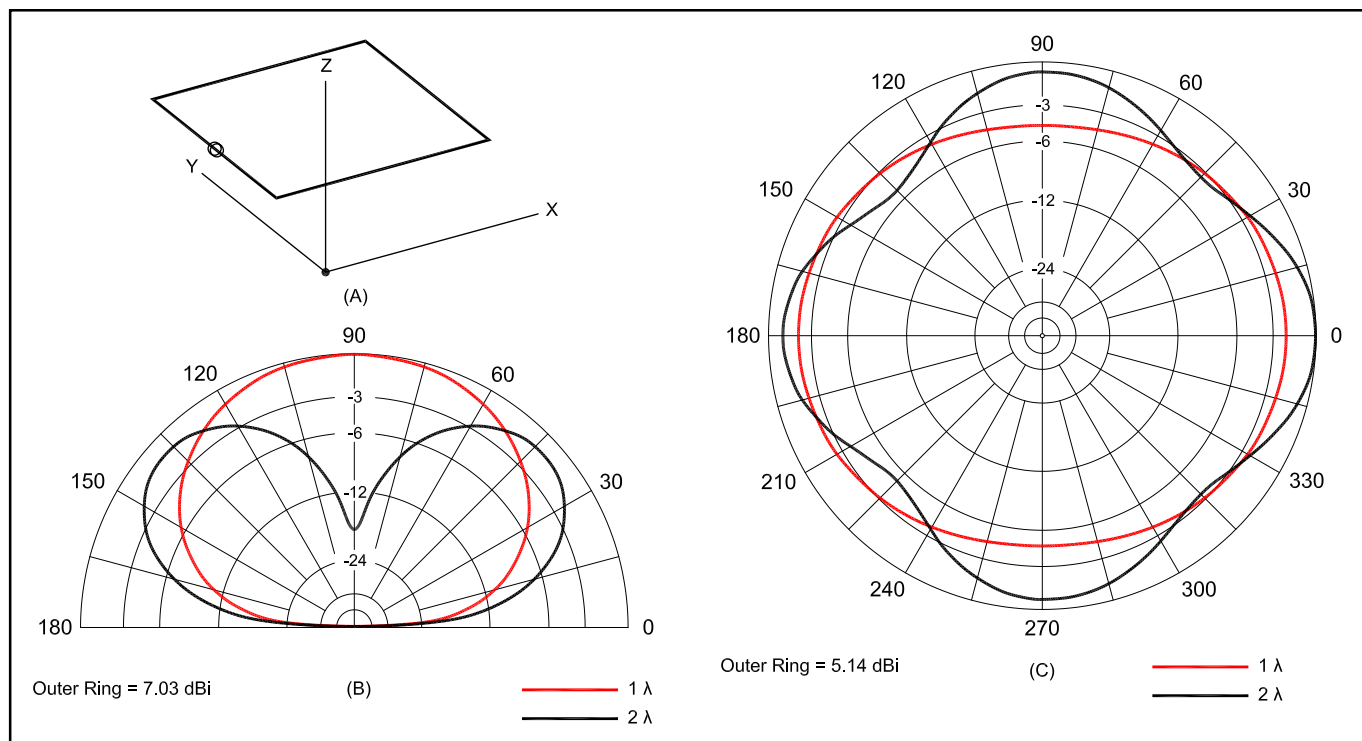

Figure 4—Elevation (B) and azimuthal (C) patterns for a 1-wavelength and a 2-wavelength horizontal loop (a 160 meter loop used for 80 meters). Note that for the 1-wavelength loop the azimuthal pattern for an elevation angle of 45° is plotted since the take-off angle is 90° .

Matching Network Capacitor Values

Let $R_1 = 6.8 \Omega$ and $R_2 = 50 \Omega$ (for a 50- Ω coaxial feed).

The series inductor $X_L = [R_1 (R_2 - R_1)]^{1/2} = [6.8 (50 - 6.8)]^{1/2} = 17 \Omega$

Because the system presents an inductive reactance of 343 Ω , cancel all but 17 Ω with a series capacitor of $(343 - 17) = 326 \Omega$ (130 pF at 4 kV rating). The impedance match is very sensitive to this reactance, so a variable capacitor is required.

The capacitor to ground $X_c = R_2 [R_1 / (R_2 - R_1)]^{1/2} = 50 [6.8 / (50 - 6.8)]^{1/2} = 19.8 \Omega$ (2139 pF). This is a low voltage capacitor—approx 300 V for 1500 W at 50 Ω —and may be of fixed value.

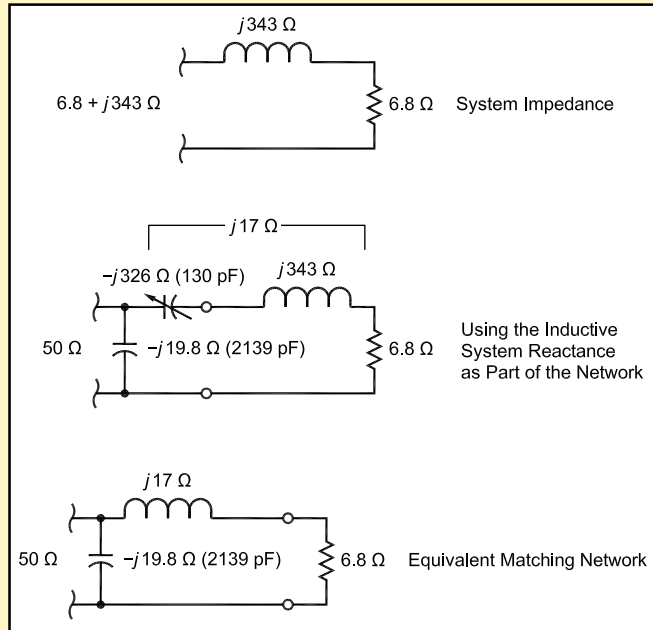

Figure A—The three steps of designing the “step-up” L-match for an inductive load.

**Table 2
System Impedance**

Frequency (MHz)	Impedance Ω
3.75	$6.8 + j343$
7.2	$135 - j37$
10.14	$67 - j12$

higher value (6.8) is the L-match network, comprising a series inductor and on the transmitter side a capacitor to ground. But we do not need the series inductor because the feedpoint impedance is already inductive. Hence what we need is a series capacitor to cancel all but the necessary matching inductance and the capacitor to ground. The author described this tuning arrangement in 1953,⁵ for matching center-loaded mobile whips. Great—we can build a simple and efficient ASTU for our 80 meter quad loop!

A Comparison with a “Sky Wire” Loop

Paul Reed, VE2LR, who intends to put up a 160 meter horizontal loop, brought to the author’s attention an article by Richard Stroud, W9SR,⁶ who has erected a 160 meter full wave horizontal or “sky wire” loop fed at a single point. He claims that his loop has “opened up a new world of DXing.” The reader of the present article may well say, “For 80 meter DX is it worthwhile feeding the opposite sides of a loop out of phase, since I can more easily put up a skywire loop?”

The 2-wavelength perimeter loop does produce a null overhead—see Figure 4. The “skywire loop” has a gain of 5.1 dBi (take-off angle 47°) at a frequency of 3.75 MHz—compared with 4.8 dBi (take-off angle 41°) for our phased loop with a heavy-duty low loss feeder (3.8 dBi if the no. 12 feeder wires are used).

However, comparing the horizontal pattern of the 2 λ skywire loop to the out-of-phase 80 meter loop in Figure 2, the latter has a nice, clean directional pattern. For the DXer who wants to work stations in a preferred direction, 4.8 dBi directive gain with a front/side ratio of about 10 dB is an attractive antenna and the 6° lower take-off angle is well worth having. Try the loop and you will see! Increasing transmitter power can to some extent replace antenna gain, but you can only work stations that you can hear.

Comparing Vertical and Horizontal Loops

At the outset it was noted that if the ground conductivity in front of the antenna was poor, horizontal was the preferred

relative phase relationships sorted out by the author by arrows. In the Case 1 model with two sources the wires have been defined so that with source current phases of 0° and 180° the pattern is as expected. Figure 3B shows clearly that the phases of currents in the wires parallel to the X-Z plane are out of phase (the desired W8JK mode). For in-phase feed (the DJ4VM antenna) of Figure 3A, the currents on the wires parallel to the Y-Z plane are in phase. With this arrangement we have a “cloud warmer” antenna.

A Practical Installation

For a practical installation of the loop the system impedance is an important consideration (as for any single band or multiband antenna system that depends on tuning feed line impedances). The impedances to match are given in Table 2 assuming the heavy-duty low loss transmission line (no. 4 wire spaced 150 mm, length 14 m).

A balanced Antenna System Tuning Unit (ASTU), or an unbalanced ASTU

with a “common subchassis” isolated internal ground, as described in the 2002 *ARRL Handbook* (pp 22.56 ff), could be used, with a 1:1 current balun between the ASTU and the transmitter. The author describes a “special ASTU” for the antenna below. [ASTU is used as opposed to the more common ATU because the tuning performed is of the complete antenna system including the feed line, as opposed to just tuning the antenna.—Ed.]

We are concerned with keeping transmission lines losses low for the loop when operated on the 80 meter band (note the high inductive reactance compared with the resistive component in Table 2). Let us now consider losses in the ASTU. Power loss in ASTUs can also be an important consideration, but in this case, the power loss in the tuner can be minimized if you fabricate a “special ASTU” for this band.

The inductive component of the system reactance could be cancelled with a series capacitor, leaving a 6.8 Ω resistive impedance. The simplest network to match the low, resistive impedance to a

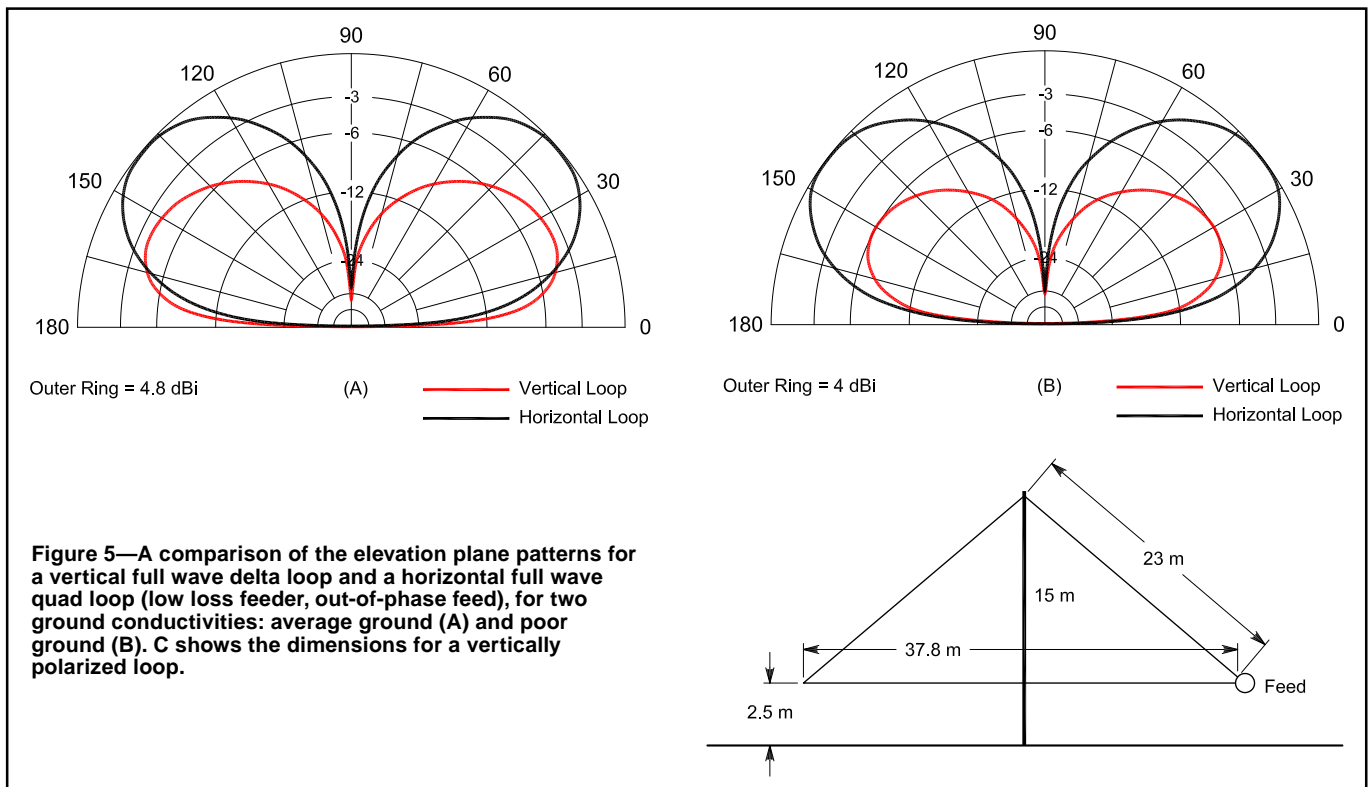

Figure 5—A comparison of the elevation plane patterns for a vertical full wave delta loop and a horizontal full wave quad loop (low loss feeder, out-of-phase feed), for two ground conductivities: average ground (A) and poor ground (B). C shows the dimensions for a vertically polarized loop.

polarization. Since the author's earlier article (Note 1) extolled the performance of vertical delta and quad loops, let us compare the performance of the horizontal quad loop with out-of-phase feed to that of a full wave delta loop on a support of the same height (15 m), for two ground conductivities: average ground ($\sigma = 5 \text{ mS/m}$, $\epsilon = 13$) and poor ground ($\sigma = 1 \text{ mS/m}$, $\epsilon = 3$). As can be clearly seen in Figure 5, for poor ground the horizontal loop wins hands down. For average ground the vertical delta loop outperforms the horizontal quad loop only for signals arriving at very low elevation angles (less than 15°).

Another consideration is background noise. The author has no side-by-side comparison of background noise for the two loop systems, vertical and horizontal, only anecdotal evidence that the noise level on a horizontal loop would be lower. Those who have used horizontal loops often report that "the residual noise level is very low," and "very seldom is the band completely dead."

A Note about Bandwidth

The antenna system bandwidth is narrow, 16 kHz (at 3.75 MHz) for a 2:1 mismatch. The operational bandwidth (estimated assuming a conjugate match) would be about 26 kHz based on the author's experience. Clearly the series capacitor should be remotely controlled.

**Table 3
System Impedance Fed In-Phase**

Frequency (MHz)	Impedance (Ω)
3.5	$383 + j1794$
3.75	$5515 + j1904$
4.0	$863 - j1595$
7.2	$102 - j1094$
10.14	$202 + j774$

Conclusions

While the horizontal loop antenna with opposite sides fed out of phase could be an excellent single-element for 80 meter DX, it is not recommended that it be the only 80 meter antenna for station use. An ordinary dipole is traditionally considered to be a necessary part of the antenna complement for operations on the 80 meter band, since a pattern optimized for high angle sky-wave, for short to medium range paths, is required for normal operation on this band.

The horizontal loop described can, however, be arranged to provide both low and high angle radiation patterns, with additional complication. If both sides of the loop are fed in phase, then we have the desired pattern for the short to medium distance range. If both sides of the loop are fed out of phase we have the desired pattern for DX. A relay located at the center of the antenna system to switch the

phase of one of the phasing lines is required to facilitate pattern selection.

This would require five supports—one for each corner and a center pole to support the phasing lines and the heavy-duty feed line. [A method to avoid the center pole would be to bring the two phasing lines directly to the ground-level system feedpoint at the center or to drop them vertically from the loop wires and then run them parallel to the ground to the center point. Doing so would alter the system feed point impedance and require changes to the matching network.—Ed.]

The ability to change patterns with the same antenna is attractive, but this requires two ASTUs because the antenna system impedance for in-phase feed is very different as shown in Table 3 (compare with Table 2).

Figure 6 shows how a remote "special ASTU" should be used for the 80 meter out-of-phase fed loop, with a coaxial cable transmission line to the "shack"; and the open wire line could be brought into the "shack" for the higher bands and for the in-phase fed loop. As an alternative, different lengths of feed line for the 80 meter in-phase fed loop could make tuning and matching more practical. This would require another transmission line relay.

Finally, if you have the room and wish to use the design for both 160 meter and 80 meter DX, make the loop twice as big (40 m on a side). This shifts concerns about keeping transmission line and

ASTU losses low to the 160 meter band. The 160 meter radiation patterns will be similar to those computed for 80 meters for our “half size” loop, and the patterns for 80 meters will be similar to those computed for 40 meters.

Acknowledgments

The author works (part time) for the Communications Research Centre Canada, Ottawa, Ontario; hence computing facilities not available to the average amateur in radio are available. In particular, the author is licensed to use the NEC-4 program.

Notes

- ¹Belrose, J.S., “Loops for 80m DX,” *QEX*, Aug 1997, pp 3-16.
- ²P. Carr, “The N4PC Loop,” *CQ Magazine*, Dec 1990, pp 11-15.
- ³J. Kraus, “The W8JK Antenna: Recap and Update,” *QST*, Jun 1982, pp 11-14.
- ⁴W. Boldt, “A New Multi-band Quad Antenna,” *Ham Radio Magazine*, Aug 1969; see also L. A. Moxon, *HF Antennas for all Locations*, published by The Radio Society of Great Britain, 1982, pp 158 and 160.
- ⁵Belrose, J.S., “Short Antennas for Mobile Operation,” *QST*, Sep 1953, pp 30-35, 108.
- ⁶Stroud, R.W., “A Large, Remote-Tuned Loop for HF DX,” *CQ Magazine*, Jul 2001, pp 44-54.

John S. (Jack) Belrose received his BAsC and

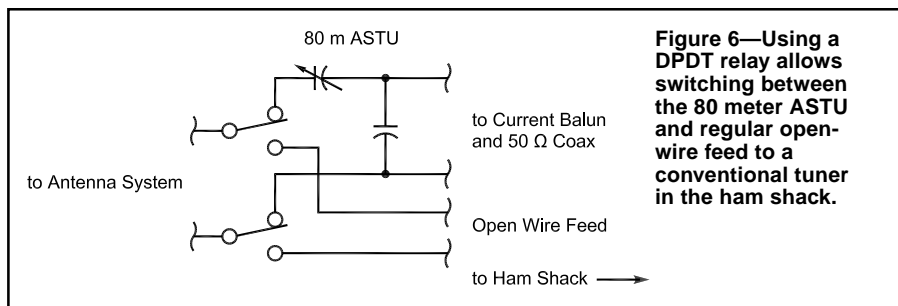



Figure 6—Using a DPDT relay allows switching between the 80 meter ASTU and regular open-wire feed to a conventional tuner in the ham shack.

MASc degrees in Electrical Engineering from the University of British Columbia, Vancouver, in 1950 and 1952. He joined the Radio Propagation Laboratory of the Defence Research Board, Ottawa, Ontario, in September 1951. In 1953 he was awarded an Athlone Fellowship, was accepted by St John’s College, Cambridge, England and by the Cambridge University as a PhD candidate, to study with the late Mr J. A. Ratcliffe, then Head of the Radio Group, Cavendish Laboratories. He received his PhD degree from the University of Cambridge (PhD Cantab) in Radio Physics in 1958. From 1957 to present he has been with the Communications Research Centre (formerly Defence Research Telecommunications Establishment), where until recently (19 December 1998) he was Director of the Radio Sciences Branch. Currently he is working (part time) at CRC

(2 days/week) devoting his time to radioscience research in the fields of antennas and propagation—a sort of transition to full retirement.

Dr Belrose was Deputy and then Chairman of the AGARD (Advisory Group for Aerospace Research and Development) Electromagnetic Propagation Panel from 1979-1983. He was a Special Rapporteur for ITU-Radiocommunication Study Group 3 concerned with LF and VLF Propagation. He is an ARRL Technical Advisor in the areas of radio communications technology, antennas and propagation; a Fellow member of the Radio Club of America and Life Senior Member of the IEEE (AP-S). He has been a licensed radio amateur since 1947 (present call sign VE2CV). You can reach the author at 17 rue de Tadoussac, Aylmer, QC J9J 1G1, Canada; john.belrose@crc.ca. 

NEW PRODUCTS

MOTRON IRX-1 INFRARED RELAY REMOTE CONTROL

◇ MoTron Electronics has introduced the IRX-1 Infrared Relay controller. The IRX-1 allows remote control of two 10-A dry-contact relays using any “learning” type remote control. There is an infrared LED on the front panel that will transmit a unique code for each relay when placed in the program mode. Simply set your learning remote to “learn” and the relay codes can be assigned to buttons on your remote.

There are two operational modes that are easily set with a DIP switch. Mode 1: Both relays are toggle on, toggle off. Each time you press the button on the remote associated with the relay it will change from on to off or off to on. An LED on the box shows the state of the relay. This mode allows for independent control of two electrical devices such as security gates, doors and so on. Mode



2: The relays will operate in a “mutually exclusive” mode. In other words, when relay one is activated it will be turned on and relay two will be turned off, if it was previously on. If relay two is activated, it will turn on and relay one will turn off. Each relay will also toggle off if its control button is pressed again when it is on. This mode lets you easily control the up/down movement of screens in meeting rooms, opening and closing of curtains and more.

Each IRX-1 can be set to an address of 1 to 16 making it possible to have up to 16 IRX-1 control units in one room. The IRX-1 is a small box measuring 2.88 × 2.3 × 1.15 inches. Connections to the relays are made through the rear with screw terminal blocks. Requires 12 V dc. Available from MoTron Electronics, 1500 Renne St, PO Box 2748, Eugene, OR 97402; tel 800-338-9058; www.motron.com. \$99.

LINEMAN TELEPHONE LINE SIMULATOR FROM DIGITAL PRODUCTS COMPANY

◇ Designed to test and demonstrate telephones, modems, fax machines and voice mail systems, the LineMan Model LM-001F allows normal operation of two connected devices and simulates a typical North American telephone line connection between them. Connected devices will “hear” standard dial tones, and the compact LineMan can generate busy signals and re-

order tones as necessary. Simply dial a seven- or eleven-digit phone number to ring the device attached to the opposite test port. The unit can be programmed to simulate typical network delays and supports rotary and tone dialing.

Price: \$239. For more information, contact Digital Products Company at 134 Windstar Cir, Folsom, CA 95630; tel 916-985-7219, fax 916-985-8460; www.digitalproductscs.com.

MAHA MH-C777PLUS-II DIGITAL BATTERY CHARGER, ANALYZER AND CONDITIONER

◇ The new Maha MH-C777PLUS-II universal charger can be used with virtually any battery pack, including those used with digital cameras, two-way radios, cellular phones, camcorders and more. The MH-C777PLUS-II offers discharge-only capacity analysis (the charger retains the discharging capacity of a battery, allowing user to rate battery performance) and an Enhanced Lithium Ion/Lithium Polymer charging algorithm (up to two times faster in Lithium Ion/Polymer charging time). The unit can digitally display the charging and discharging capacity of the battery pack, as well as real-time battery voltage and charging times. \$89.99. See your favorite dealer, or contact: Maha Energy, 545-C W Lambert Rd, Brea, CA 92821; tel 800-376-9992; www.mahaenergy.com/. 